

APPENDIX A

SUBJECT: MacPherson strut cartridge replacement on GM-10 series ("W"-car) vehicles. This includes 1988 and later Pontiac Grand Prix, Oldsmobile Cutlass and Buick Regal, 1989 and later Chevrolet Lumina.

PROBLEM: A MacPherson strut spring compressor is not required to replace the MacPherson struts on these vehicles. The strut cartridge is removed and replaced through the body shock tower. Special tools are required.

W-CAR TOOL SUPPLIERS

COMPANY	PHONE
Branick #GMW-594	1-800-437-4394
GP Tool # GP2013-8 w/ #GP2013-12	1-800-223-0555
Schley #88400	1-714-693-7666
Specialty #88802 w/ # 88805	1-800-525-6505



CAUTION:

Do not service the strut unless the vehicle is on the floor. All 4 tires must be on the floor and facing straight ahead, otherwise the coil spring can fly free.

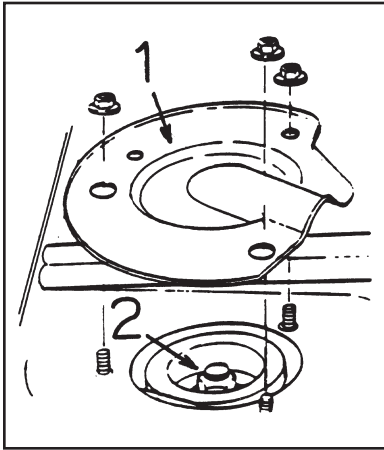

1. Remove the three nuts and the strut mount cover (Item 1). Remove the strut piston rod nut (Item 2).

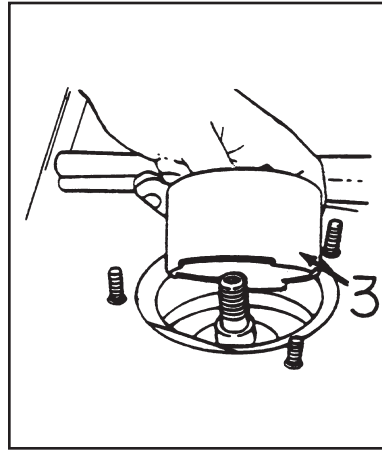

2. Remove the strut mount bushing (Item 3) by prying with a suitable tool.

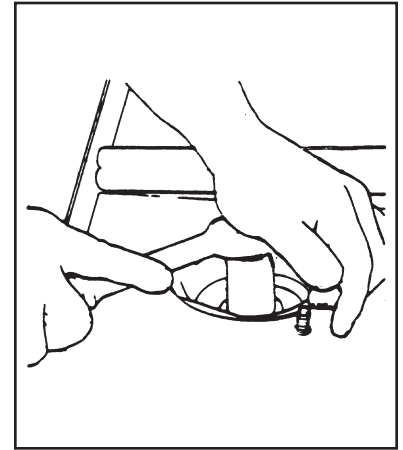

3. Remove the jounce bumper retaining plate using a special tool. Rotate tool counterclockwise to remove.

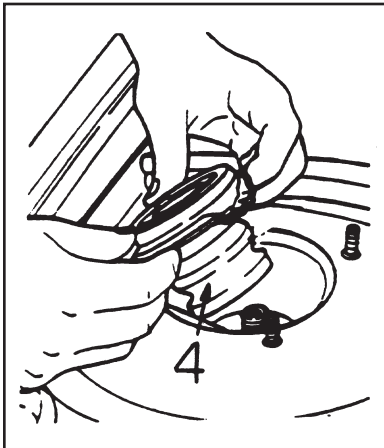

4. Remove the jounce bumper (Item 4).

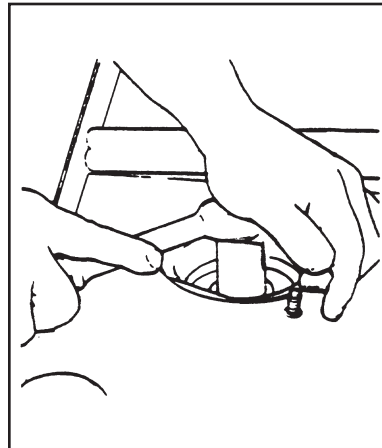

5. Remove the strut cartridge retaining nut using a special tool.

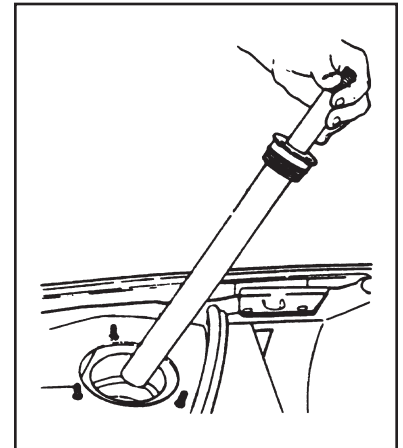

6. Remove the strut cartridge and replace with a new unit. Replace all components in reverse order of disassembly. Torque cartridge retaining nut and all nuts and bolts to manufacturer's specifications.

APPENDIX B

SELF LEVELING SYSTEM ELECTRONIC COMPRESSOR DEACTIVATION PROCEDURE FOR GM MODELS

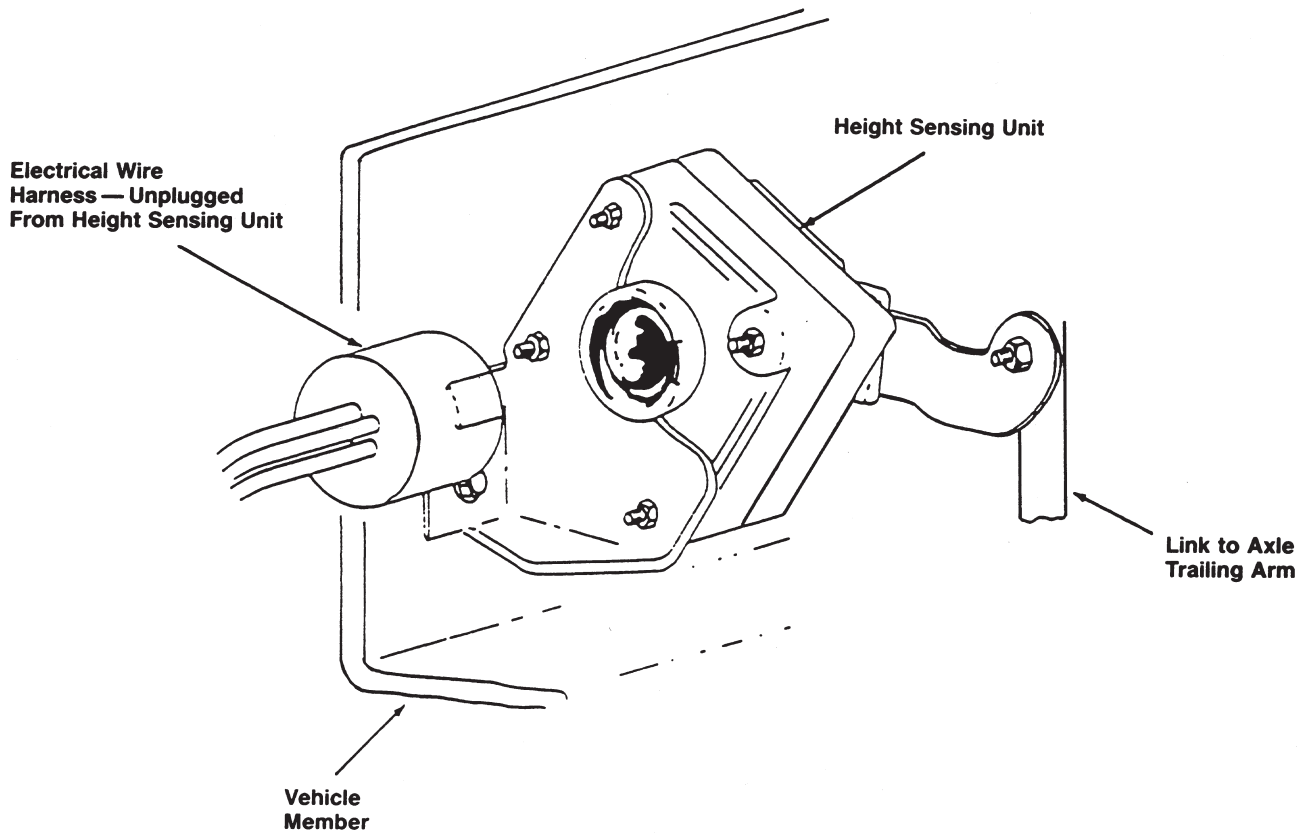

When installing conventional shock absorbers on GM models equipped with self-leveling rear suspension that uses an electronic compressor, the following procedure should be used:

- 1) Locate height sensing unit on under body of vehicle approximately above the rear axle. Locate a small link connected to the rear axle trailing arm. The upper end of this link will be connected to the electronic height sensing unit.
- 2) Unplug electrical wire harness from the height sensing unit. System is now deactivated.
- 3) Cover exposed electrical connector with tape or other suitable material and secure to underside of vehicle.
- 4) It is Not necessary to disconnect link to axle trailing arm.

APPENDIX C

ELECTRONIC SUSPENSIONS AIR SUSPENSIONS AND ELECTRONIC LEVEL CONTROLS

Occasionally a customer will inquire if their vehicle's electronic suspension, air suspension or rear electronic level control can be replaced with standard components. The following chart will assist you in determining answers to these inquiries.

VEHICLE/SYSTEM

GM, FORD, CHRYSLER FULLSIZE AND INTERMEDIATES

Electronic level control ELC; known also as air shocks, air struts.

In most cases, standard shocks and struts can be installed if the ELC System is disarmed. Refer to Appendix B for one such disarming procedure.

LINCOLN CONTINENTAL, MITSUBISHI GALANT, SUBARU

Air suspension struts; i.e.,

These systems cannot be substituted for without extensive vehicle modification. KYB does not recommend removal.

DODGE STEALTH 1991-96 with ECS (Electronic Controlled Suspension)

1. Remove front struts and rear shock activators.
 2. Unplug control module behind right rear trim panel.
 3. Remove and install struts and shocks per instruction sheet supplied with units.
 4. Use the following units: 335013 Front, 341184 Rear (2 W/D), 341185 Rear (4 W/D).
-

CHEVROLET CORVETTE 1990-94 — with ERC (Electronic Ride Control)

1. Remove shock actuators.
 2. Unplug ERC module located in rear cargo area.
 3. Remove & install shocks per instruction sheet supplied with units.
 4. Use the following units: KG5570 Front, KG5571 Rear.
-

FORD PROBE GT 1989-92 — with PRC (Programmed Ride Control)

1. Remove strut actuators.
 2. Unplug PRC module located under the passenger seat.
 3. Remove & install struts per instruction sheet supplied with units.
 4. Use the following units: 235046 Right Front, 235047 Left Front, 235606 Rear.
-

FORD THUNDERBIRD SUPER COUPE 1989-96 with PRC (Programmed Ride Control)

This system cannot be substituted without extensive vehicle modification. KYB Does Not Recommend Removal.

FORD THUNDERBIRD TURBO COUPE 1987-88 with PRC (Programmed Ride Control)

1. Remove strut and shock actuators.
 2. Unplug PRC module located in the trunk behind rear seat.
 3. Remove & install struts and shocks per instruction sheet supplied with units.
 4. Use the following units: 235008 Front, KG5556 Rear.
-

MAZDA MX6 GT 1988-92 — with AAS (Auto Adjust Suspension)

1. Remove strut actuators.
 2. Unplug AAS module located in the trunk.
 3. Remove & install struts per instruction sheet supplied with units.
 4. Use the following units: 235046 Right Front, 235047 Left Front, 235606 Rear.
-

MAZDA RX7 TURBO 1989-92 & MAZDA RX7 GXL 1986-88 with AAS (Auto Adjust Suspension)

1. Remove strut and shock actuators.
 2. Unplug AAS module located in the trunk.
 3. Remove and install struts & shocks per instruction sheet supplied with units.
 4. Use the following units: 235012 Right Front, 235013 Left Front, KG9132 Rear.
-

MAZDA 323 1986-89 — with ASA (Adjustable Shock Absorber)

1. Remove strut actuators.
 2. Unplug control switch connector behind the dash.
 3. Remove & install struts per instruction sheet supplied with units.
 4. Use the following units: 234008 Right Front, 234009 Left Front, 232011 Right Rear, 232012 Left Rear.
 5. NOTE: The front upper mount must be replaced with a standard OE upper mount.
-

MAZDA 626 1988-92 with AAS (Auto Adjust Suspension)

1. Remove strut actuators.
 2. Unplug AAS module located in the trunk.
 3. Remove & install shocks per instruction sheet supplied with units.
 4. Use the following units: 235046 Right Front, 235047 Left Front, 235606 Rear.
-

MAZDA 626 1983-87 — with AAS (Auto Adjust Suspension)

1. Remove strut actuators.
 2. Unplug AAS module located in the trunk.
 3. Remove & install struts per instruction sheet supplied with units.
 4. Use the following units: 233007 Right Front, 233008 Left Front, 234050 Rear.
-

MERCURY COUGAR XR7 1987-88 with PRC (Programmed Ride Control)

1. Remove strut and shock actuators.
 2. Unplug PRC module located in the trunk behind rear seat.
 3. Remove & install struts and shocks per instruction sheet supplied with units.
 4. Use the following units: 235008 Front, KG5556 Rear.
-

MERCURY COUGAR XR7 1989-96 with PRC (Programmed Ride Control)

This system cannot be substituted without extensive vehicle modification. KYB Does Not Recommend Removal.

MITSUBISHI 3000 GT 1991-99 with ECS (Electronic Controlled Suspension)

1. Remove front struts and rear shock activators.
 2. Unplug control module behind right rear trim panel.
 3. Remove and install struts and shocks per instruction sheet supplied with units.
 4. Use the following units: 335013 Front, 341184 Rear (2 W/D), 341185 Rear (4 W/D).
-

MITSUBISHI MONTERO 1992-96 with VSA (Variable Shock Absorbers)

1. Remove shock activators.
 2. Unplug control module behind left rear trim panel.
 3. Remove and install shocks per instruction sheet supplied with units.
 4. Use the following units: KG54302 Front, KG54303 Rear.
-

NISSAN 300ZX 1984-89 with ECVSA (Electronically Controlled Variable Shock Absorber)

1. Remove strut and shock actuators.
 2. Unplug ECVSA control module per Kit 108A instruction.
 3. Remove & install cartridges and shocks per instruction sheet supplied with units and Kit 108A.
 4. Use the following units: 365056 Front, KG5787A Rear.
 5. NOTE: Conversion Kit 108A (1 req.) necessary to convert entire vehicle. The original rear shock bumpers are not reusable.
-

NISSAN 300ZX 1990-95 with ECVSA (Electronically Controlled Variable Shock Absorber)

1. Remove shock actuators.
 2. Unplug the ECVSA control module.
 3. Remove & install shocks per instruction sheet supplied with units.
 4. Fire/drill open round hole ($\frac{1}{2}$ " i.d.) in front shock upper insulator.
 5. Fire/drill open ($\frac{7}{16}$ " i.d.) the rear shock upper mount spacer.
 6. Use the following units: 341149 Right Front 341150 Left Front, 341151 Rear.
-

NISSAN MAXIMA 1989-94 with Nissan Sonar Suspension II

1. Remove strut actuators.
 2. Unplug NSS module located in the console.
 3. Remove and install struts & shocks per instruction sheet supplied with units.
 4. Use the following units: 235051 Right Front, 235052 Left Front, 365079 Rear.
-

NISSAN MAXIMA 1985 with ECVSA (Electronically Controlled Variable Shock Absorber)

1. Remove the strut actuators.
 2. Unplug ECVSA module located in the trunk.
 3. Remove & install struts per instruction sheet supplied with units.
 4. Replace the front strut mounts with KYB #SM5065 and the front upper spring seats, thrust seats, and strut tower covers with Nissan P/N's: 54040-05E00, 54043-01E00, and 54380-05E00. Two each of these 4 P/N's are required.
 5. Use the following units: 235030 Right Front, 235031 Left Front, and 365080 Rear.
-

NISSAN MAXIMA 1986-88 with ECVSA (Electronically Controlled Variable Shock Absorber)

1. Remove the strut actuators.
 2. Unplug ECVSA module located in the trunk.
 3. Remove & install struts per instruction sheet supplied with the units.
 4. Replace the front strut mounts with KYB #SM5065 and the front upper spring seats, thrust seats, and strut tower covers with Nissan P/N's: 54040-05E00, 54043-01E00, and 54380-05E00. Two each of these 4 P/N's are required.
 5. Use the following units: 235019 Right Front, 235020 Left Front, and 365080 Rear.
-

NISSAN PATHFINDER 1987-95 with ASA (Adjustable Shock Absorber)

1. Remove shock actuators.
 2. Unplug control switch located in console.
 3. Remove & install shocks per instruction sheet supplied with units.
 4. Use the following units: KG5476 Front, KG5438 Rear.
-

TOYOTA CRESSIDA 1986-88 with TEMS (Toyota Electronic Modulated Suspension)

1. Remove shock actuators.
 2. Unplug TEMS module located behind the right rear trim panel.
 3. Remove & install shocks per instruction sheet supplied with units.
 4. Use the following units: N/A Front, 343042 Rear.
-

TOYOTA SUPRA MAR. 1986-91 with TEMS (Toyota Electronic Modulated Suspension)

1. Remove shock actuators.
 2. Unplug TEMS module located under the dash.
 3. Remove & install shocks per instruction sheet supplied with units.
 4. Use the following units: 341069 Front, 341070 Rear.
-